

DIESELJET

625

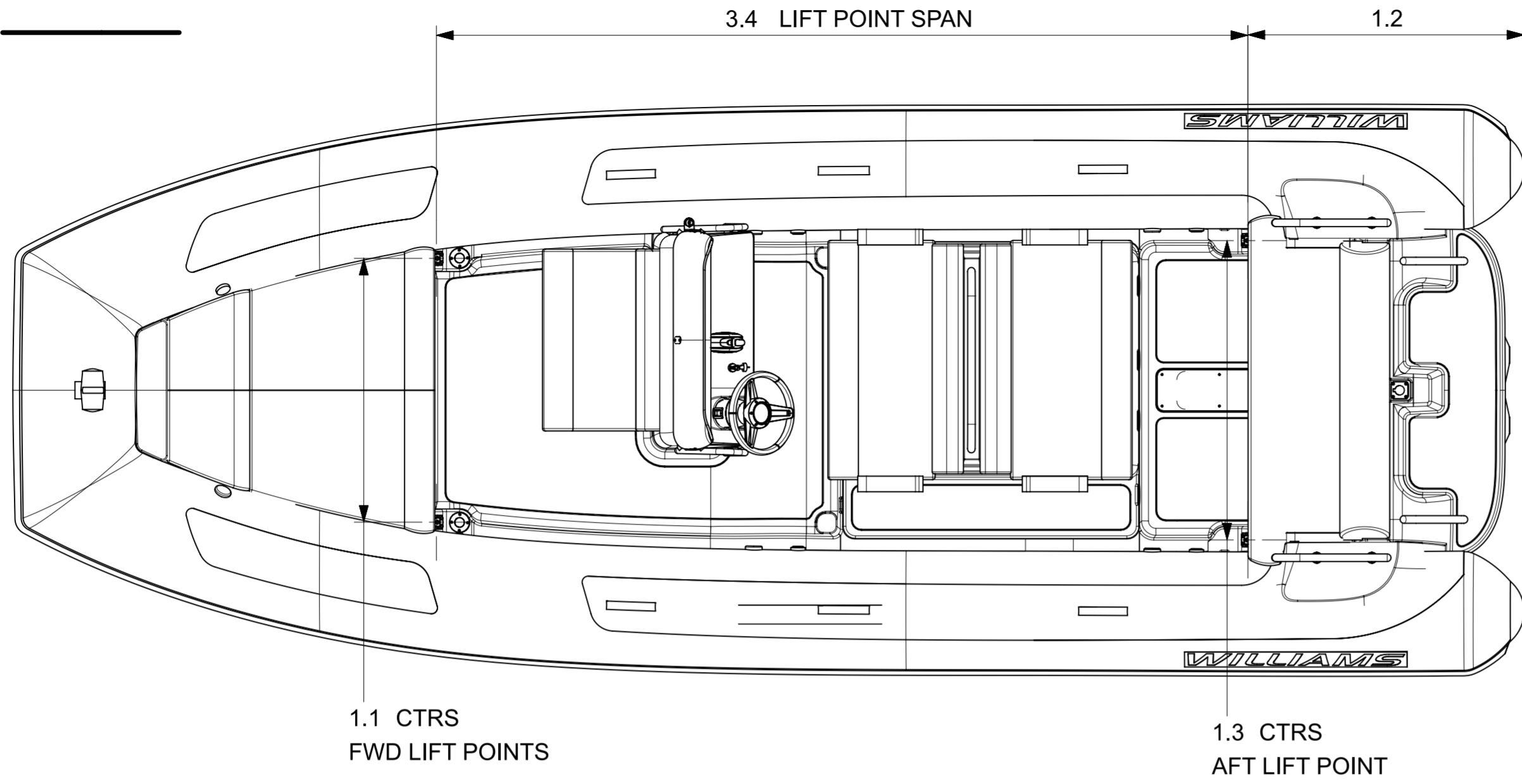

LENGTH	6.32m (±1%)
BEAM	2.39m (±1%)
DRAFT (FULLY LOADED)	0.50m
ENGINE	YANMAR 4LV
POWER	195hp ≅ 145kW
	230hp ≅ 172kW
DRY WEIGHT	1310Kg
SEATING CAPACITY	11
FUEL	DIESEL
FUEL CAPACITY	140L
MAX. SPEED	44mph ≅ 71kph
	46mph ≅ 74kph
No. TUBE COMPARTMENTS	6
CE DESIGN CATEGORY	C

NOTES:

1. LENGTH / BEAM TOLERANCE DUE TO VARIATION IN TUBE AIR PRESSURE.
2. AVERAGE 230HP MODEL DRY WEIGHT STATED; ACTUAL WEIGHT DEPENDENT ON OPTIONS FITTED.
3. LOW PROFILE OPTION:
 - REMOVABLE BACKREST
 - QUICK RELEASE STEERING WHEEL
 - FOLDABLE WINDSCREEN
 - FWD TUBE DEFLATED
4. REFER TO DWG RD444 FOR CHOCK PROFILES.

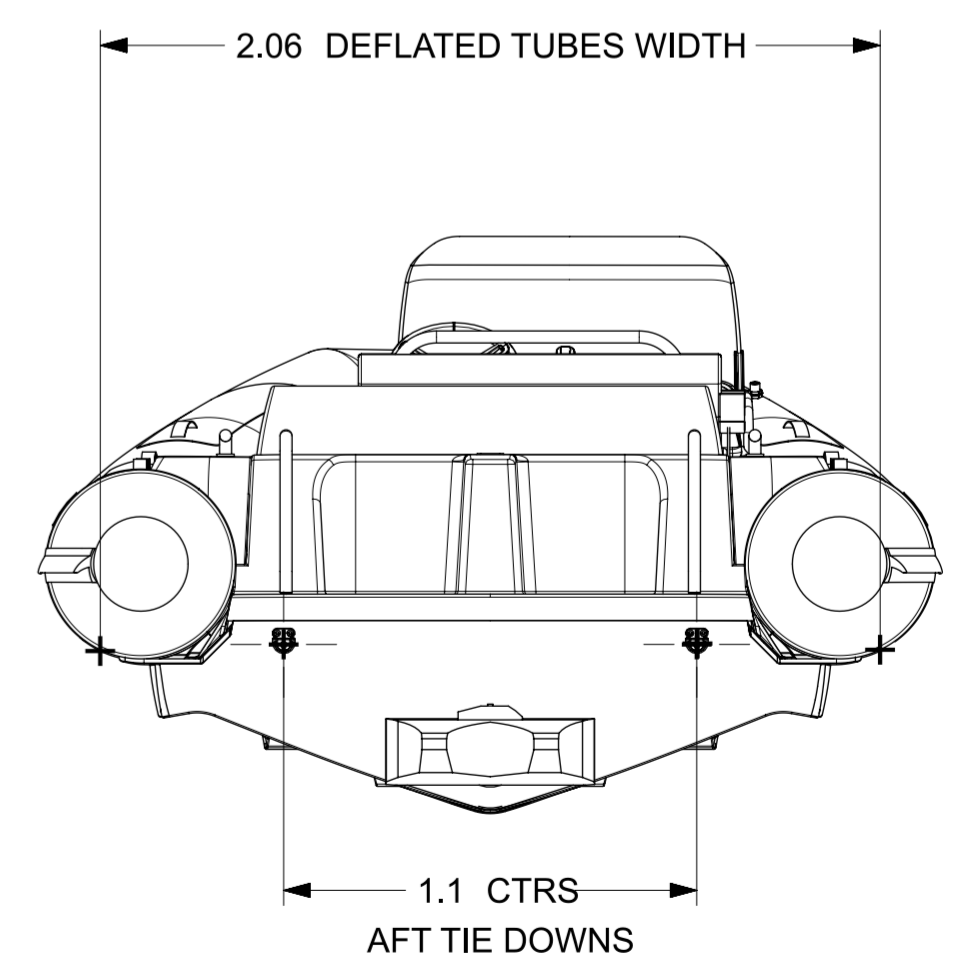
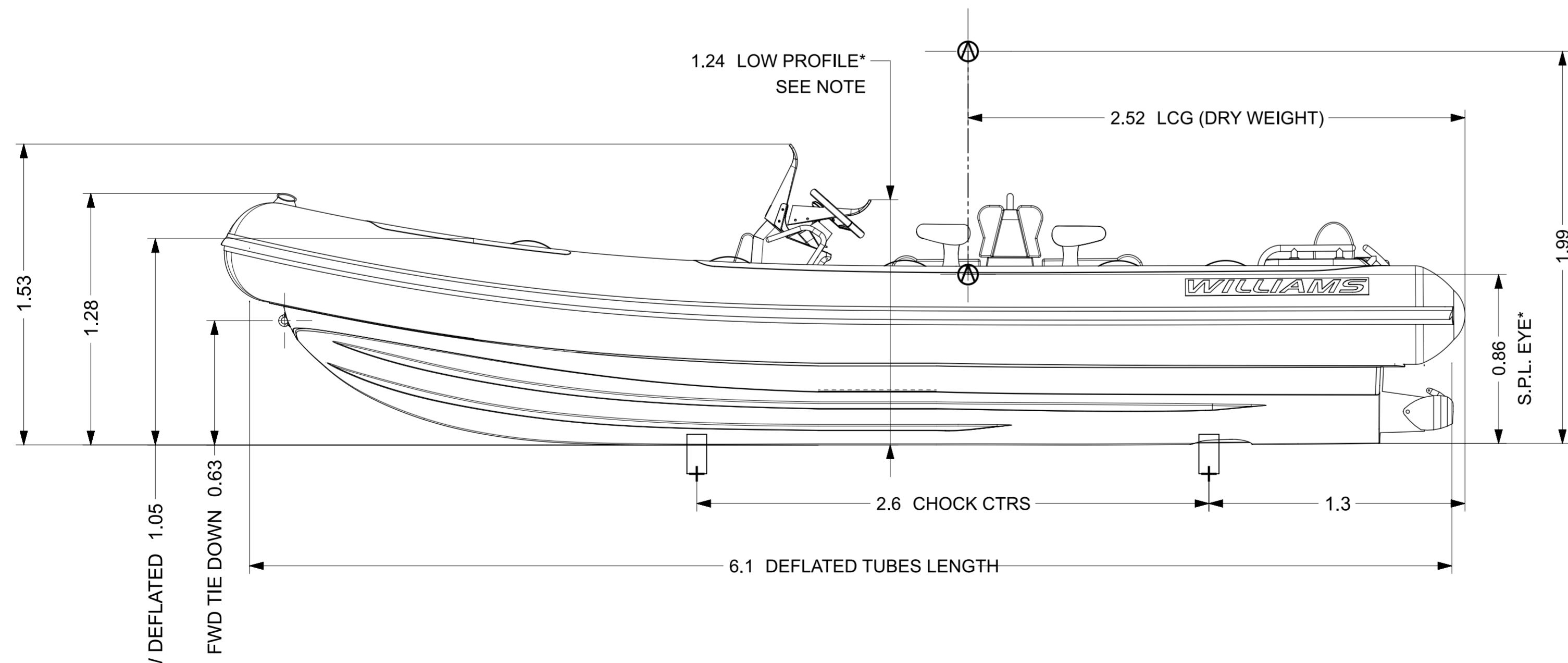

*OPTIONAL ACCESSORY

REV.	DATE	DETAILS	DRAWN	APP'D
1	12/08/2021	DOCUMENT PRODUCTION	WE	DBS

GENERAL TOL.	0	+0.50
	0.0	+0.25
	0.00	+0.10
	0	+0.50*

DRAWN	WE	DATE	12/08/2021
APP'VD	DBS	DATE	12/08/2021
PROJECT:	-		
INSPECTION LEVEL:	N/A		
MATERIAL & FINISH	-		

WILLIAMS

DIESELJET 625 (2022MY)

PART NO. WPT-000625DJ-2022MY-DATASHEET-dwg.1

SCALE 1:20

SHEET 1 OF 1

NOT FOR PUBLICATION - THIS DRAWING IS THE PROPERTY OF WILLIAMS JET TENDERS LTD. AND IS ISSUED ON CONDITION THAT IT IS NOT COPIED, RE-PRINTED OR DISCLOSED EITHER WHOLLY OR IN PART TO ANY THIRD PARTY NOT AUTHORISED TO RECEIVE IT

REMOVE ALL BURRS & BREAK SHARP EDGES
GENERAL SURFACE FINISH Ra 1.6UM
DIMENSIONS IN MM UNLESS STATED
DO NOT SCALE DRAWING