

HIGH PERFORMANCE

**HIGH-PERFORMANCE PROPULSION
FOR MARINE PROFESSIONALS**

**VOLVO
PENTA**



An aerial photograph of an offshore wind farm. In the foreground, a large white wind turbine stands prominently. In the middle ground, a small service vessel is moving across the blue water, leaving a white wake. Other wind turbines are visible in the distance. The sky is clear and blue.

WHEN TIME IS TIGHT

A service vessel on its way to repair a malfunctioning wind power station, a marine ambulance racing to assist at the scene of an accident, or a coast guard vessel intercepting a suspected smuggler – in almost every marine profession, time is the most critical factor. It's often the difference between a successful operation and a failure

WHEN TIME IS TIGHT, professional marine operators must be able to trust their equipment and, in particular, their boats. Here, the key to functionality, to uptime and to performance is the boats' engines and drivelines.

The world of marine professionals is the world of Volvo Penta. For more than 100 years, we have been developing, designing, manufacturing and servicing marine drive systems that meet all the demands of heavy-duty applications in marine environments.

We are proud that operators in a variety of areas and businesses, all over the world, put their trust in our ability to provide outstanding power for marine professionals.

THIS IS VOLVO PENTA.

AN **INCLUSIVE** OFFER

Through long-lasting cooperation with operators, designers, manufacturers and classification societies, we know your business from within. But we also know your desire to get the best out of leading-edge technology, drive a profitable operation and meet environmental demands.

LONG-TERM PARTNERSHIP

Our core products are the Volvo Penta engines, but our offer to you goes far beyond that. Innovative drive systems and accessories, outstanding fuel efficiency and reliability, and a global service dealer network bring about a partnership for performance and profitability in the long term.

A VOLVO GROUP COMPANY

As part of the Volvo Group, we proudly uphold the Volvo heritage and benefit from the group's tremendous expertise and technology resources. Our leading-edge automotive technology, adapted for marine environments, has given us a strong position in the market.



IT'S ALL ABOUT **UPTIME** AND **TOTAL COST OF** **OWNERSHIP** – AND **LONG-TERM THINKING**

When it comes to propulsion engines in marine commercial applications, the key to a profitable operation is minimizing the total cost of ownership and maximizing engine uptime.

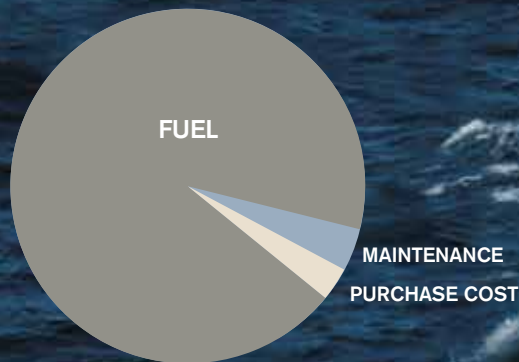

Our global network of dealers provides reliable support for your operation – with just **one point of contact** for the whole package: engines, instruments, accessories, service, warranties, etc. It's safe, secure and simple.

MAXIMAL UPTIME

The robust Volvo Penta engines are renowned for their high performance and reliability. This makes them perfect for demanding marine propulsion applications – and provides the best conditions for maximal uptime.

THE VITAL FUEL COST

Fuel consumption accounts for the largest portion of your total operational cost. That is one reason why marine operators all over the world have selected the extremely fuel-efficient Volvo Penta power systems.

QUICKLINE

Quickline is Volvo Penta's production line for customers operating commercial vessels. If an engine breaks down, Volvo Penta can produce a new engine* in seven days. With this exclusive service, your downtime is reduced to a minimum.

EXTENDED COVERAGE

With Volvo Penta's Extended Coverage program, you can prolong the standard warranty with up to five years – or the corresponding number of running hours – of full coverage for the complete Volvo Penta package: from helm station, engines, drives, to the propellers.

* Classified and non-classified 300- to 750-hp D9MH, D13MH or D16MH propulsion engines. Please contact your nearest Volvo Penta dealer for detailed information.

WITH





YOU ALL THE WAY

FIND YOUR DEALER

You will find your nearest Volvo Penta dealer on volvopenta.com or download our dealer locator app.



GLOBAL SERVICE AND SUPPORT

The network of qualified and skilled Volvo Penta service dealers covers around 130 countries and is constantly growing. As an operator or OEM, you are offered tailor-made service and support offerings with everything you need to secure optimal uptime and cost of ownership over the engine's life cycle.

A SELECTION OF TAILOR-MADE OFFERINGS

- Preventive maintenance
- Service agreement
- Technical training
- Oil analysis
- Exchange components
- Repair and overhaul kits
- Repowering

EFFICIENT LOGISTICS AND PARTS SUPPLY

Volvo Penta dealers stock the parts appropriate to their local market. If a part is not held in stock by your dealer, the Volvo Group – with its world-class global parts distribution network – will provide fast delivery, with special routines for breakdowns, wherever you operate.

VOLVO ACTION SERVICE 24/7

Volvo Action Service provides you with breakdown and online technical support in Europe, North America and in large areas of Africa, the Middle East, Asia Pacific (India, China, South East Asia, Korea, Japan), Russia and Turkey.

ONLINE SERVICES FOR PARTNERS

As an OEM, you have access to the Volvo Penta Partner Network, the online service that provides access to technical and warranty information as well as parts ordering.

These are examples from the wide service and support range offered by Volvo Penta and our dealers. Please note that offerings can vary between markets.

EVC AT WORK

By fully integrating a boat's engines, electronics and unique optional functions to one platform, the type-approved Volvo Penta EVC (Electronic Vessel Control) provides outstanding performance and safety.

With all information collected in one CAN-bus backbone, the amount of wiring and number of connectors is radically reduced, resulting in higher reliability and easier installation.



EASY TO USE AND EXPAND

With the EVC, you can easily master and monitor all functions through the controls and displays. The EVC provides full monitoring, protection and diagnostics for both engine and transmission – as well as increased control.

All updates are simple to perform, and the broad range of smart accessories and new functions are easy to install.

EVC FOR OPTIMAL PERFORMANCE

The unique Volvo Penta EVC functions are easily mastered and monitored through the controls and displays.

KEEP YOUR BOAT STILL AND STEADY

Hold your boat's position and heading practically still and steady with the Dynamic Positioning System – for safe maneuvering when waiting to refuel or preparing for offloading of equipment and personnel at an offshore site.

PRECISE AND ACTIVE MANEOUVRING

Use Joystick Driving to steer comfortably – with precision – at all speeds, just by pushing and rotating the joystick. The EVC system is easily interfaced with a number of autopilots.

EASY, HIGH-PRECISION DOCKING

With Joystick Docking, every docking maneuver is rapid and exact. Just move the joystick in any direction and your boat will follow.

PERFECT TRIM – PERFECT BALANCE

The robust interceptor trim system, IS, provides optimal boat attitude in all conditions and increased visibility during acceleration and in sharp turns.

AT YOUR SERVICE

The 7" color display shows all available information the way you want it: digital or analogue readers, tailored or standard view, etc. for up to three engines.





	Volvo Penta IPS	Sterndrive	Inboard
Joystick Docking	○	○ (1)	
Joystick Driving	○	○ (1)	
Dynamic Positioning System*	○		
Autopilot**	○	○ (1)	
Interceptor System	○	○	○
Powertrim Assistant		○	
Glass Cockpit*	○	○	○
Trip computer	○	○	○
Cruise control	○	○	○
Single-lever mode	○	○	○
Low-speed mode	○		○

1) Requires factory-installed electronic steering

* Not covered by type approval

** Not wheel marked

Not all functions are available for type approved installations, for detailed information, please contact Volvo Penta.

Function availability depends on EVC generation, for detailed information, please contact Volvo Penta.

SIMPLE AND SAFE

To make Volvo Penta EVC as safe and reliable as possible, we have based it on a unique and simple concept:

- ONE system, including all engines and all functions.
- ONE company responsible for design and testing.
- ONE point of contact for the whole system.
- ONE method of installation for manufacturers.
- ONE tool for service technicians.
- ONE interface for operators.

HIGH-PERFORMING IN EVERY ASPECT

The unique, type-approved Volvo Penta IPS system is well-proven by operators all over the world who value performance, maneuverability, and on-board comfort.

The key to these exceptional qualities is the forward-facing, twin counter-rotating propellers and individually steerable pods under the hull.

IMPROVE YOUR WORKING ENVIRONMENT

Significantly reduced vibration and noise levels increase on-board comfort and make for better working conditions.

SAVE TIME WITH ACTIVE MANEUVERING

All IPS vessels offer easy and precise maneuvering. This makes docking procedures time-efficient and cuts turnaround time.

DEVELOPED, MANUFACTURED AND SERVICED BY ONE COMPANY

With Volvo Penta you need just one point of contact for the complete IPS package: engines, drives, propellers, instruments, accessories, service, warranties etc.

Thanks to the unique marine torque, excellent fuel efficiency, first-class maneuverability, and reduced environmental impact, the Volvo Penta IPS meets the demands for any of your high-performance commercial applications. Each IPS installation is a complete and perfectly matched propulsion package – guaranteeing optimum performance in all conditions.

FORWARD-FACING PROPELLERS WORK MORE EFFICIENTLY

With IPS, the propellers work in undisturbed water. All power drives the boat forward and the propeller thrust is parallel with the hull. Forward-facing propellers also mean that all exhaust fumes are emitted through the pods and dispersed well behind the boat. And with the propellers positioned well beneath the keel line, air intrusion – and cavitation – is stopped.



- FORWARD-FACING EFFICIENCY
- VIRTUALLY NO FUMES
- CAVITATION-FREE

THE BENEFITS* OF VOLVO PENTA IPS

- 40% LONGER CRUISING RANGE
- 20% HIGHER TOP SPEED
- 30% REDUCED FUEL CONSUMPTION
- 30% LESS CO₂ EMISSIONS
- 50% LOWER PERCEIVED NOISE LEVEL
- SAFE AND PREDICTABLE HANDLING
- JOYSTICK

* Compared with inboard shafts at cruising with planing hulls, approximate figures.

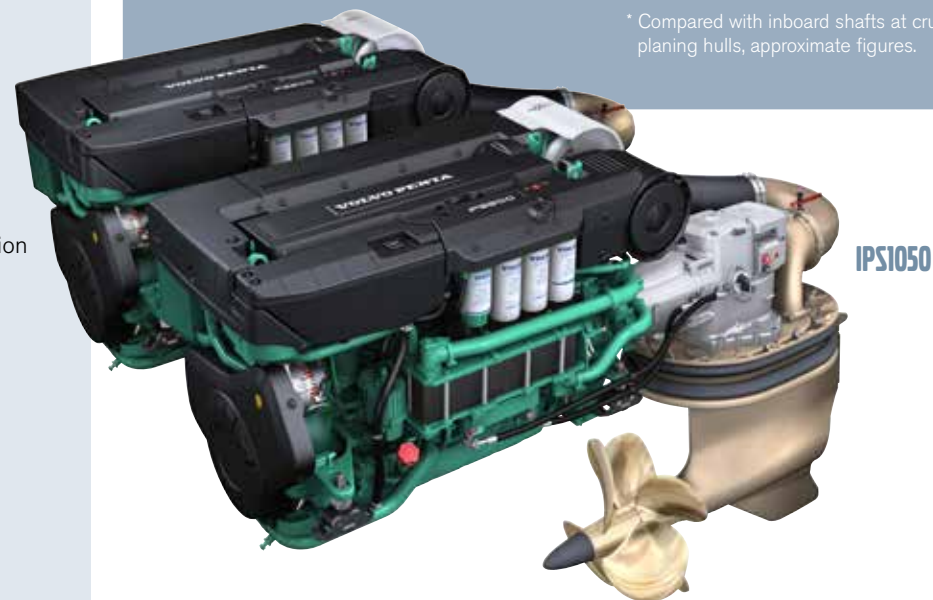

IPS1050





IPS APPLICATION CHART

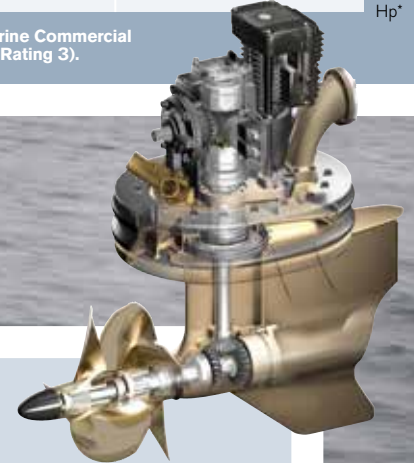
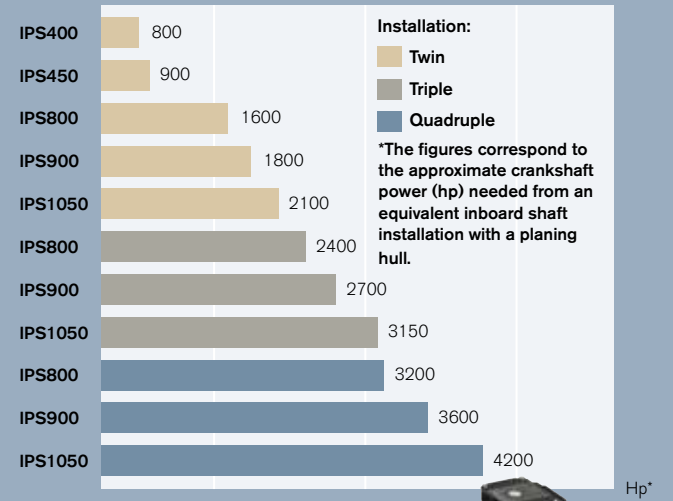

TYPE APPROVED BY DNV

The Volvo Penta IPS system is covered by type approval for the engine, IPS drive and EVC system in accordance with DNV's rules for High Speed & Light Craft, based on SOLAS High Speed code.

The Volvo Penta IPS 900 can also be supplied with a product certificate covering the complete system, from helm station to propeller, for vessels requiring fully classified machinery in accordance with DNV's High Speed & Light Craft rules.



THE WORLD'S LEADING STERNDRIVE

In its own unique way, the Aquamatic sterndrive offers a total solution for operators who want an optimal combination of high speed, acceleration, fuel efficiency and comfort in boats 20 to 45 feet.

It's a perfectly matched package – from controls to engine, drive and propellers – available with a wide range of fuel-efficient and reliable diesel engines.

BETTER WATER GRIP

The counter-rotating propellers – the Duoprop – provide unequalled performance, responsive handling and excellent grip in the water. All propellers are perfectly matched to a specific drive and application.

IMPROVE PERFORMANCE WITH EVC

The EVC platform further improves the performance of

your Aquamatic, with a range of features for easier handling, increased safety and improved vessel control.

MAKE STEERING SIMPLER AND MORE EFFICIENT

An Aquamatic installation can also be delivered with an EVC joystick steering system.

D6

THE BENEFITS OF AQUAMATIC STERNDRIVE

- LOW FUEL CONSUMPTION
- LOW CO₂ EMISSIONS
- LOW NOISE AND VIBRATIONS
- JOYSTICK

A MATCHING RANGE

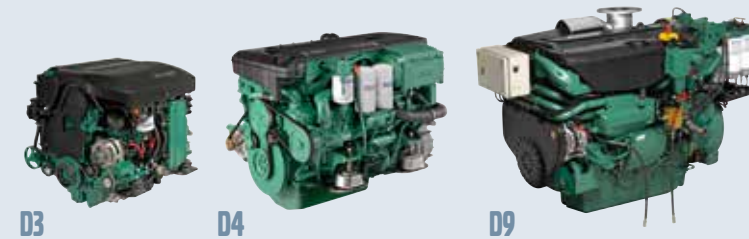

THE D3 SERIES

This 5-cylinder D3 is extremely lightweight and compact. With features such as common rail fuel injection system, variable geometry turbocharger, and EVC, it offers world-class diesel performance and low emissions.

THE D4 SERIES

From the latest design in modern diesel technology, the 4-cylinder D4 comes equipped with common rail fuel injection system, turbocharger and aftercooler. Combined with EVC, this results in low emissions and first-class diesel performance.

THE D6 SERIES

With features such as common rail fuel injection, turbocharger, compressor, aftercooler, and EVC, the 6-cylinder D6 is state-of-the-art in modern diesel technology. This results in exceptional diesel performance and low emissions.



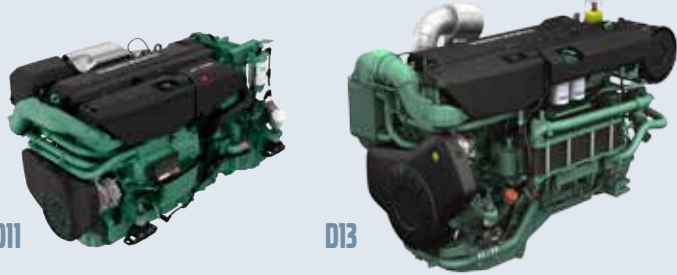

D11

D13

THE D9 SERIES

The top-modern in-line, 6-cylinder D9 diesel engine has a robust block with ladder frame, high pressure unit injector system, “twin entry” turbo and aftercooler. With EVC, this results in smooth running, and low fuel consumption and emissions.

THE D11 SERIES

This extremely powerful and compact 6-cylinder D11 engine features a unique twin-entry turbo that facilitates magnificent torque for powerful acceleration. This strong and highly efficient engine offers excellent reliability and long action range.

THE D13 SERIES

As a smooth-running engine, the in-line, 6-cylinder D13 combines world-class diesel performance with low fuel consumption and emissions. This engine offers features such as a high-pressure unit injector system, “twin entry” turbo, aftercooler and EVC.

THE D16 SERIES

The in-line, 6-cylinder D16 diesel features a robust block with ladder frame, “twin entry” turbo and charge air cooler. The heat exchanger combined with the injection system and the engine management system further improves performance and drivability.



D16

A VARIETY OF APPLICATIONS

Volvo Penta type-approved engines together with the EVC or MCC system can be used for any high-performance propulsion system arrangement or requirement.

FPP

The excellent load-carrying capability of the Volvo Penta engines makes them a perfect match for fixed-pitch propeller applications. A range of transmissions is available for different speeds and duty profiles.

CPP

With our high-performance engines, controllable pitch can easily be optimized for different operating conditions, such as transit mode and cruise. Volvo Penta solutions are easily integrated with different transmissions and control systems.

WATERJET

Volvo Penta engines are a perfect match for any type of waterjet, in terms of power/rpm range as well as engine response time.

SURFACE DRIVES

Thanks to their unique marine torque, Volvo Penta engines are an ideal power source for demanding surface drive applications.





SUSTAINABLE DEVELOPMENT

Economic growth and environmentally sustainable development are the major challenges of our time. Each year, the Volvo Group devotes numerous resources to developing products that meet our customers' demands for reliable high performance, as well as minimal environmental impact.

Being environmentally aware – and acting accordingly – is not only a matter of conscience. Today, it's a competitive edge and, more often, also a legal demand.

We will continue to work in close cooperation with our partners and customers and remain at the forefront of technological and environmental development – today, tomorrow and in the future.

Because time is tight, also in an environmental perspective.

**VOLVO
PENTA**